



Project: Our Lady of Fatima Catholic School
Site Work
Chatham, Ontario
SCCDSB 619-CP1706

Project ID: ROA16-050

Addendum: 1

Attention: Project Bidders

Date: May 05, 2017

This Addendum is hereby made a part of the Contract Documents and modifies the original Bidding Documents as noted below. The following additions, deletions and amendments shall be incorporated into the bid submission.

1.1 Refer to Specification Section 00 21 13 Instructions to Bidders, 1.5 Site Assessment

- .1 Mandatory Site Examination and Bidder's Briefing
 - .1 See Bidder's Briefing Log attached herewith in this addendum for eligible bidders.

1.2 Refer to Specification Section 00 00 10 List of Contents

- .1 Delete reference to 04 00 00 Masonry Sections

1.3 Refer to Drawing AS-102

- .1 Delete Construction Note S06 at Existing Transformer Pad. Existing Transformer wall to remain

1.4 Refer to Mechanical | Electrical Drawings

- .1 See enclosed Mechanical | Electrical Addendum #1

END OF ADDENDUM

PREPARED BY THE CONSULTANT

Joseph Ouellette

Project Manager | ROA Studio

Signature

05-05-2017

Date: MM.DD.YEAR



Jilani and Asuncion Consulting Engineers

LONDON, ON | 519.902.2956 | 416.828.4004 | WWW.JACENG.CA

ADDENDUM

ME No. 01

Architect:	ROA studio inc.	Attention:	Joseph Ouellette
Project:	Our Lady Fatima Catholic School Site Work 545 Baldoon Road, Chatham, On	Project No.:	17-012
Date:	May 4, 2017	Issued By:	Mohammed Jilani, P.Eng.

This addendum becomes part of the tendered contract document package and amends the original bidding requirements, drawings and specifications as noted below.

Document	Description
RFI May 1, 2017	<p><u>Request For Information:</u></p> <ol style="list-style-type: none"> 1. Can you please supply a detail for steel angle frame support for Fixture Types A. Who supplies and install's the support bracket? 2. For fixture types B mounted at 12' is it possible to run feed through school in $\frac{1}{2}$" EMT conduit and pop out with BX cable at locations shown rather than run rigid conduit along parapet on roof and mount junction boxes. You would then have to have teck cable hanging over the ledge. Also many LED wall packs do not have a provision for top entry. 3. Can the same be done for fixture type A? If not can we run through the school with EMT conduit to the exterior wall and then pop through the roof and install aluminum conduit along parapet from there.
Mechanical Electrical Drawings ME-101 and ME-102	<ol style="list-style-type: none"> 1. RFI Responses: <ol style="list-style-type: none"> a. Re question 1, See detail of fixture type 'A' installation as per attached sketch ME 102.1. The Electrical Contractor supplies and installs all supporting brackets for Trunion mounting on the wall such that the installation will allow enough clearance for aiming from -30° to +60° off horizon. b. Re question 2, 3/4" minimum, see response to question 3.

Jilani and Asuncion Consulting Engineers

LONDON, ON | 519.902.2956 | 416.828.4004 | WWW.JACENG.CA

ADDENDUM

ME No. 01

	<p>c. Re question 3, route EMT through the school to exterior wall and then pop through the wall and install aluminum conduit along exterior (just below parapet coping) to each fixture.</p>
<p>Mechanical Electrical Drawings ME- 101 and ME-102</p>	<p>1. NEW ITEM: Disconnect and remove existing wall mounted fixtures on the east and west facades (total of 5) and turn them over to owner. Remove wiring back to source and patch and repair holes left behind after removal.</p>

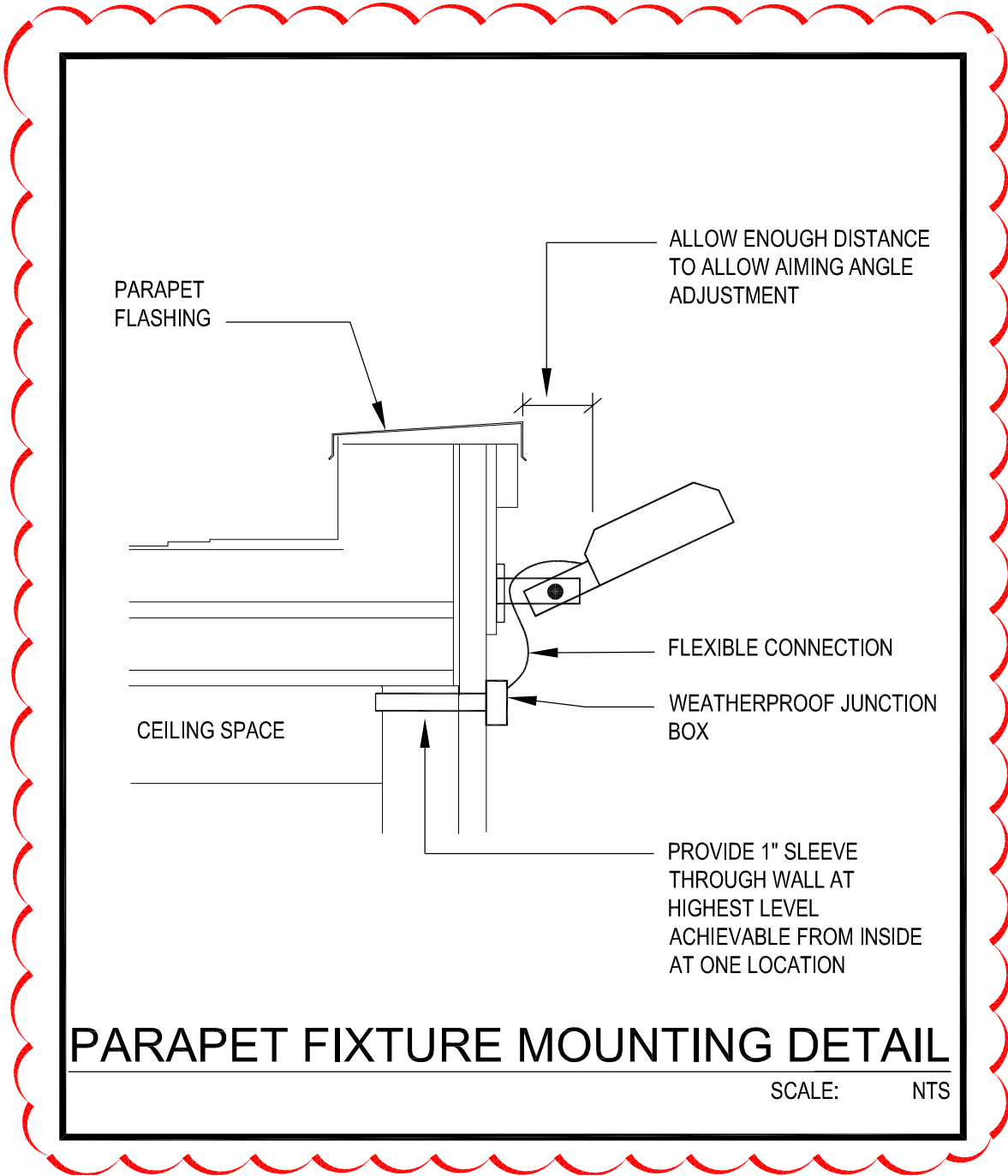

**Jilani and Asuncion
Consulting Engineers**

LONDON, ON | 519.902.2956 | 416.828.4004 | WWW.JACENG.CA

JACE #17-012

PROJECT

**Our Lady Fatima Catholic School Site
Work, 545 Baldoon Rd, Chatham, On**

DRAWING

Parapet Fixture Mounting Detail

Issued For:

Addendum ME-01

Drawn By:

JL

Checked By:

MGJ

Date:

May 4, 2017

Scale:

NTS

Dwg No.

ME 102.1



Project: Our Lady of Fatima Catholic School
Site Work
Chatham, ON

Project ID: ROA16-050
Client ID: 640-CP1706
Site Briefing: 1

Attention: Project Bidders

Date: April 28, 2017

A **Mandatory Bidder's Briefing** has been scheduled for April 28, 2017 beginning at 9:30h (9:30am). All invited parties will meet at the Main Entrance of St. Our Lady of Fatima Catholic School, 545 Baldoon Road, Chatham, ON. The Site may not be available for viewing at any time. All contractors are invited. Attendance will be taken and the Bidders List finalized from those in attendance. Pre-qualification will not be accepted from Bidders who do not attend the **Mandatory Bidder's Briefing**.

SECTION A: MANDATORY BIDDER'S BRIEFING LOG - Described above

NAME:	REPRESENTING:	EMAIL:	PHONE No.	FAX No.
Joseph Ouellette	ROA studio inc.	joseph@roastudio.com	519.397.0943	519.480.0645
David Pollard	ELric Construction	info@elricconstruction.com	519 627-6031	519-627-0101
Bill HOEKSTRA	B.H.G.C	INFO@bh-gc.com	519 344 4515	519 344 3336
STEVE CALABRESE	NEW RISE DEMOLITION	STEVE@NEWRISEDEMOLITION.CA	519 652-4008	519 652-1518
Bob Koomans	ALBI	m.timmermans@albi.ca	519-683-4445	519-683-4674
BILL MASON	WESTHOEK CONSY.	BILL@WESTHOEK.ON.CA	519-351-4221	519-351-7150
Joe Calabrese	Henry Heyink Const	joe@heyink.on.ca	514-354-4543	514-354-9191
Jordan Hoelstra	Dig' R Wright	digrwright@ciaccess.com	519-352-3805	514-260-9144
John Koomans	Dick Koomans & Sons Ltd	koomansdemo@coyeco.net	519-352-4389	519-352-9450
Peter Harris	HARRIS BROS	harris.bros@coyeco.net	519 357 5150	519 357 9444

